



Plug-in current transformers

for busbar 50 x 12 mm

SW-S 5010

Type SW-S 5010

Width	85 mm
Depth	40 / 58 mm
Busbar size	50x12 / 2x40x10 mm
Round cond.	Ø 44 mm

Accessories incl. foot fastening brackets
busbar fixing material
secondary terminal cover

Weight approx. 450 g
Special design in class 0,2S and calibrated CTs on request.

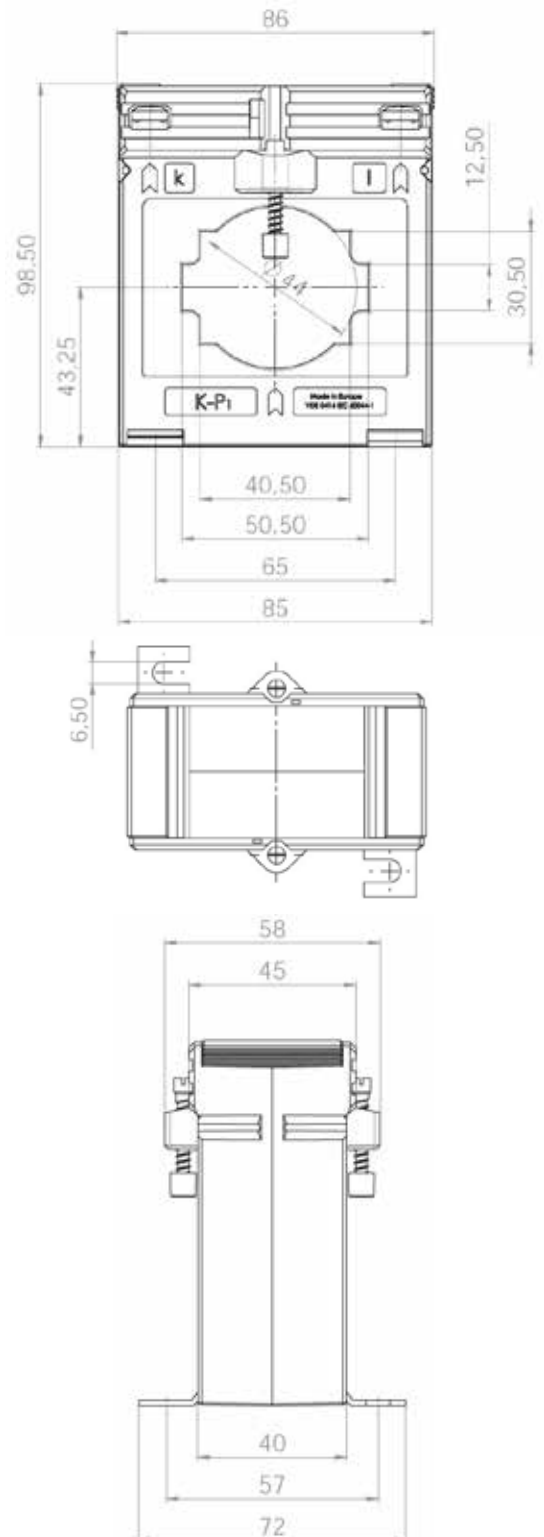

Types and variants

Primary current in A	VA	class 1		class 0,5	
		sec. 5 A	sec. 1 A	sec. 5 A	sec. 1 A
100	1,5	X	X	-	-
150	1,5	X	X	X	X
	2,5	X	X	X	X
200	2,5	X	X	X	X
	5	X	X	X	X
250	2,5	-	-	-	-
	5	X	X	X	X
	10	X	X	-	-
300	2,5	-	-	X	X
	5	X	X	X	X
	10	X	X	-	-
400	2,5	-	-	X	X
	5	X	X	X	X
	10	X	X	X	X
500	5	-	-	X	X
	10	X	X	X	X
	15	X	X	X	-
600	5	-	-	X	X
	10	X	X	X	X
	15	X	X	X	X
750	5	-	-	X	X
	10	X	X	X	X
	15	X	X	X	X
800	5	-	-	X	X
	10	X	X	X	X
	15	X	X	X	X
1000	10	X	X	X	X
	15	X	X	X	X
	30	-	-	-	-
1200	10	X	X	X	X
	15	X	X	X	X
	30	X	X	-	-
1250	10	X	X	X	X
	15	X	X	X	X
	30	X	X	-	-

Accessories: see accessories