

**Form A (Flachkupfer)**

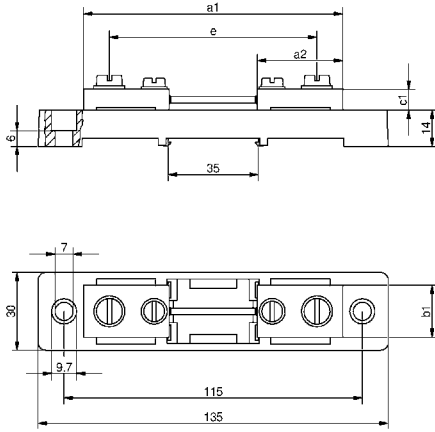

**Form B (L-Kupfer)**

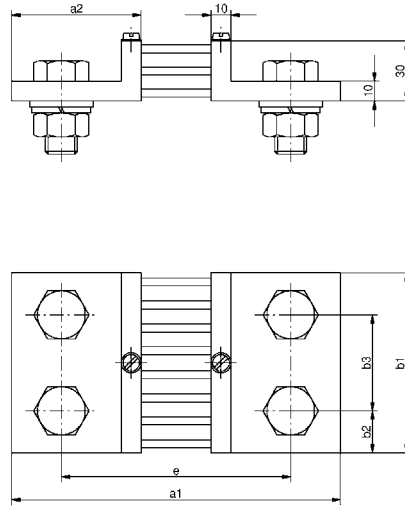

**Form C (T-Kupfer)**

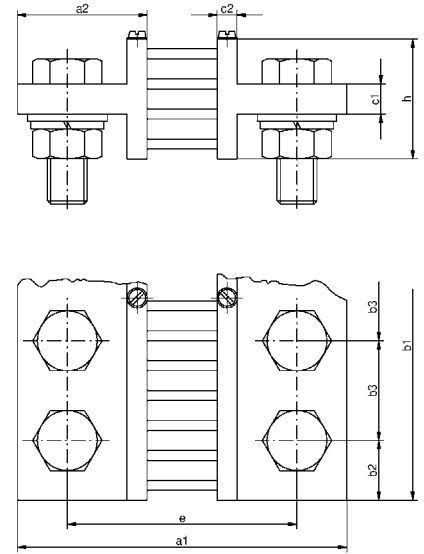

**Isoliersockel bis 25 A**

**Abmessungen 60 mV**

Nennstrom	Form	a1	a2	b1	b2	b3	c1	c2	h	e	n <sup>1</sup>	s <sup>2</sup>
<b>A</b> bis 25	A	100	33	20			8			78	2	M 6
40-150	A	100	33	20			8			80	2	M 8
200 / 250	A	145	55	30			10			105	2	M 12
300	B	145	55	30	15					105	2	M 12
400 / 500 / 600	B	145	55	40	20					105	2	M 16
800 / 1000 / 1200	B	165	65	60	30					115	2	M 20
1500	B	165	65	90	21	48				115	4	M 16
2000 / 2500	B	165	65	120	30	60				115	4	M 20
3000	B	165	65	150	45	60				115	4	M 20
4000 / 5000	C	165	65	120	30	60	15	10	60	115	4	M 20
6000 / 7000	C	175	70	154	25	52	25	15	130	125	6	M 20
8000	C	175	70	206	25	52	25	15	130	125	8	M 20
10000	C	185	75	206	25	52	30	20	170	135	8	M 20
12000	C	185	75	258	25	52	30	20	170	135	10	M 20
15000	C	185	75	310	25	52	30	20	170	135	12	M 20
20000	C	185	75	414	25	52	30	20	170	135	16	M 20

1 = n: Anzahl der Schrauben

2 = s: Schrauben nach ISO 4017

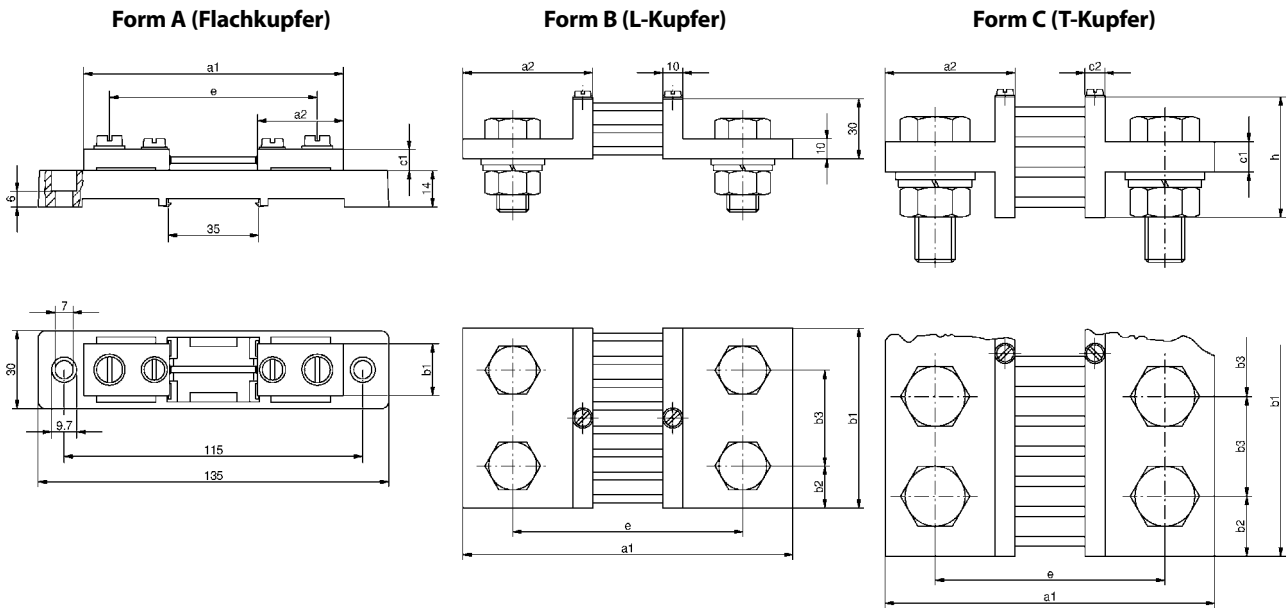

Isoliersockel bis 25 A		Abmessungen 100 mV											
Nennstrom	Form	a1	a2	b1	b2	b3	c1	c2	h	e	n <sup>1</sup>	s <sup>2</sup>	
<b>A</b>	bis 25	A	100	33	20		8			78	2	M 6	
	40-150	A	150	33	25		8			131	2	M 8	
	200 / 250 / 300	B	195	55	30	15				155	2	M 12	
	400 / 500 / 600	B	195	55	40	20				155	2	M 16	
	800 / 1000 / 1200	B	215	65	60	30				165	2	M 20	
	1500	B	215	65	90	21	48			165	4	M 16	
	2000	B	215	65	120	30	60			165	4	M 20	
	2500 / 3000	C	215	65	120	30	60	15	10	60	165	4	M 20
	4000 / 5000	C	215	65	135	37,5	60	15	10	60	165	4	M 20
	6000 / 7000	C	225	70	154	25	52	25	15	130	175	6	M 20
8000 / 10000	C	235	75	206	25	52	30	20	170	185	8	M 20	

		Abmessungen 150 mV											
Nennstrom	Form	a1	a2	b1	b2	b3	c1	c2	h	e	n <sup>1</sup>	s <sup>2</sup>	
<b>A</b>	bis 25	A	100	33	20		8			78	2	M 6	
	40-150	A	225	33	25		8			205	2	M 8	
	200 / 250	B	270	55	30	15				230	2	M 12	
	300 / 400 / 500 / 600	B	270	55	40	20				230	2	M 16	
	800 / 1000 / 1200	B	290	65	70	35				240	2	M 20	
	1500 / 2000	C	290	65	90	21	48	15	10	60	240	4	M 16
	2500 / 3000	C	290	65	120	30	60	15	10	60	240	4	M 20
	4000 / 5000	C	300	70	120	30	60	25	15	130	250	4	M 20
	6000 / 7000	C	300	70	154	25	52	25	15	130	250	6	M 20
	8000 / 10000	C	310	75	206	25	52	30	20	170	260	8	M 20

1 = n: Anzahl der Schrauben  
 2 = s: Schrauben nach ISO 4017